

2023 NORDIC CHAMPIONSHIP TRIAL RULES

DEFINITION OF A TRIAL

A Trial is an event in which the skill and regularity of the riders form the basis of the results. Sections are included within the course, where the skill of the rider negotiating them is observed and penalties given. In addition, a time limit is set for part of, or for the whole course.

The course may consist of cross-country terrain, country lanes, and woodland tracks etc.



The Championship will be organized according to the date set at the Annual Meeting of the Nordic Motorsport Council (NMC) of the previous year. The date will preferably be in August, not colliding with European or World Trial Championship rounds. The Individual Championship will take place on the Saturday, followed by the Team Championship on the Sunday.

NMC NORDIC INDIVIDUAL & TEAM CHAMPIONSHIP, JUNIOR NORDIC CHAMPIONSHIP, OVER 40 NORDIC CHAMPIONSHIP, LADIES NORDIC CHAMPIONSHIP & OPEN NORDIC CLASS

TL 01.1 GENERAL

TL 01.1.1 NMC Standards for the Organizers

TL 01.1.2 Meeting with the Organizers

TL 01.2 JURISDICTION

TL 01.3 COURSE

TL 01.3.1 Distance

TL 01.3.2 Course marking

TL 01.4 SECTIONS

TL 01.4.1 Section boundaries

TL 01.5 TIME ALLOWANCE AND CONTROL

TL 01.5.1 Time measurement

TL 01.5.2 Individual Time Allowance

TL 01.5.2.1 Increase in Individual Time Allowance

TL 01.5.3 Starting Time and Control

TL 01.5.4 Lap Time Control

TL 01.5.5 Time allowance in sections

TL 01.6 PRACTICING

TL 01.7 RIDERS INSPECTION OF THE SECTIONS

TL 01.7.1 Inspection of the Sections prior to the event.

TL 01.7.2 Inspection of the Sections during the event.

TL 01.8 ADMINISTRATION

TL 01.8.1 Rider's licenses

TL 01.8.2 Submission of entries

TL 01.8.2.1 Non-participation in an event

TL 01.8.2.2 Team participants and categories

TL 01.8.2.2.1 Participants

TL 01.8.2.2.2 The Nordic Team Trial Championships

TL 01.8.2.2.3 The Nordic Junior Team Trial Championship

TL 01.8.2.2.4 The Nordic Women's Team Trial Championship

TL 01.8.2.2.5 The Nordic 40+ Team Trial Championship

TL 01.8.2.2.6 Minders

TL 01.8.3 Entry fee

TL 01.8.4 Rider's bibs

TL 01.8.5 Registered Assistant (Minder)

TL 01.8.6 Starting interval

TL 01.8.7 Starting order

TL 01.9 TECHNICAL

TL 01.9.1 Equipment of Motorcycles

TL 01.9.2 Riders Equipment

TL 01.9.3 Sound level Control.

[TL 01.10 PENALTIES](#)

TL 01.10.1 Time Penalties with respect to Time Allowances

TL 01.10.2 Penalty Points in a Section during the Trial

TL 01.10.2.1 Definition of Fault

TL 01.10.2.2 Definitions of Failure

TL 01.10.2.3 Extra Sanction Points

TL 01.10.2.4 Obstruction

TL 01.10.3 Yellow Card

TL 01.10.4 Disqualification

[TL 01.11 RECORDING OF SCORES](#)

[TL 01.12 RESULTS AND CLASSIFICATION](#)

TL 01.12.1 Event Results and Classification

TL 01.12.2 Final Classification

[TL 01.13 PREMATURE STOPPAGE](#)

[TL 01.14 TIES](#)

TL 01.14.1 Ties at the end of the event

TL 01.14.2 Ties at the end of the Championship

[TL 01.15 AWARDS](#)

TL 01.15.1 Prize Giving Ceremony and Public interview

TL 01.15.2 Penalty for non-attendance

[TL 01.16 PROTESTS](#)

TL 01.1 GENERAL

The NMC has established the Nordic Championships according to the rules of the FIM Europe Sporting Code and the other Codes as well as this appendix.

The Nordic Championship is open to riders from the year they turn 13 years, and are from a FIM Member FMN.

Riders from the year they turn 13 years of age are allowed to ride a bike with maximum cylinder cubic of 125cc.

Riders **from the year they turn 16** are allowed to ride a bike **with cylinder volume** greater than 125cc.

The Junior Nordic Championship is restricted to riders from the year they turn 13 years of age and who are under, or attain, 18 years during the current year and are from a FIM Member FMN.

The +40 Nordic Championship is restricted to riders who are 40 years during the current year and from a FIM Member FMN.

The Ladies Nordic Championship is open to riders from the year they turn 13 years of age, are from a FIM Member FMN.

One or more Open Classes should be included in each event for riders from the year they turn 13 years of age who will compete either in one of the other classes section route or a own.

NB: There is no overall classification for these class/classes.

The Nordic championship 2019 is suggested to host a competition class +60 informed in the supplementary regulations and held if there is a sustainable number of competitors. This class shall follow white markings.

TL 01.1.1 NMC Standards for Organizers

The NMC has established the Nordic Trial Championships according to the rules of the FIM Europe Sporting Code and the other Codes as well as this appendix. However, exceptions to the use of the FIM Europe Codes are written in this appendix.

TL 01.1.2 Meeting with the Organizers

A meeting will be held between the organizers and the Jury President at 10:00, one day prior to the event. This meeting shall include the following persons: the President of the Jury, the Clerk of the Course, the Secretary of the meeting, the person responsible for the Sections. Other persons who the Jury President or the Organizer feels appropriate may attend.

TL 01.2 JURISDICTION AND SAFETY

A Nordic Jury composed of a Jury President appointed by the FMNR.

Each FMN who has a rider competing in the event may send a Delegate (Licensed National Clerk of the Course) to attend all open meetings of the Jury. The Jury Delegate can report any observations to the Clerk of the Course or at the open Jury meetings. The Jury Delegate has no jurisdiction over the Observers or other Officials and must not discuss any concerns directly with them.

The national medical codes can be used, but the minimum medical requirement are:

- Medical doctor or certified emergency personnel from rescue service or similar has to be present.
- An emergency ambulance must be present on the event within a minimum of 20 minutes
- Room for examination of patients.

TL 01.3 COURSE

The route should be in one direction only. If, in exceptional circumstances, two-way traffic is unavoidable, then special safety measures must be taken, e.g. separating the track or

positioning of officials. It must be possible for the riders to complete the course (from the paddock to all sections and back) without the use of public roads (unless closed for general traffic with permission from the authorities and guarded by police or officials).

To be classified as a finisher the rider alone shall ride or push his machine for the entire distance of the Course, unless the organizers have authorized other assistance or authorized deviation.

TL 01.3.1 Distance

The length of the course for each lap shall not exceed 20 km.

The Trial shall consist of 3 laps for Championship men, women & Junior classes, a minimum of 2 laps for the +40 and other classes.

TL 01.3.2 Course marking

The course shall be marked with arrows as shown below or by the use of ribbon that are similar to the ribbons used in the sections. If the organizer chooses to use ribbons they will still have to make some number markings there where this is necessary.

Within the square mark there shall be written the number of the section to which the arrow directs the riders. All markers must be made of waterproof material.

During the event the marked route must be strictly followed. A rider who leaves the route must, under penalty of disqualification, regain the course at the point where he left it.

The course shall be marked the day before the event and the riders will be allowed to follow it by motorcycle under their own responsibility during the scheduled inspection of the sections (see TL 01.7.1).

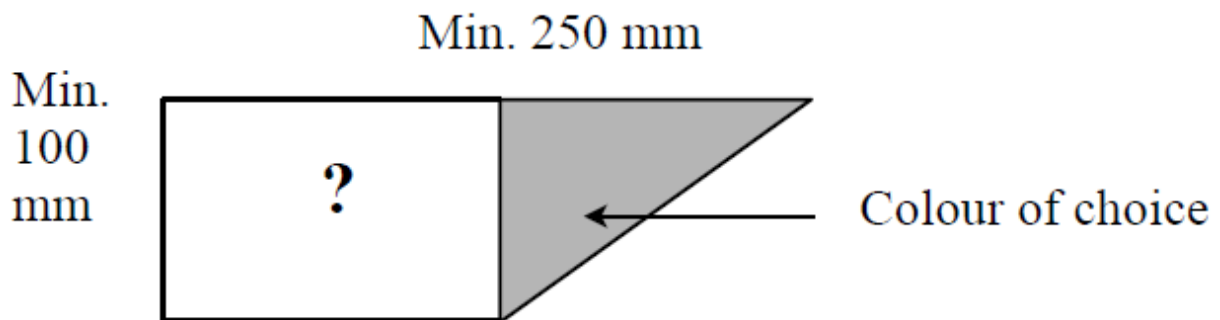

For safety reasons, there shall wherever possible, be a route marked for spectators, which is different to that marked for the riders.

TL 01.4 SECTIONS

The number of sections shall be 12 per lap.

For each class the sections must be designed so that at least 1/3 are of an easy, medium and difficult level. Each section shall be completely independent of other sections. Sections constructed predominantly with industrially processed elements or materials should be avoided and can eventually be abandoned by the jury.

Each section must be clearly numbered in consecutive order and the rider must, under penalty of 10 points, attempt the sections in numerical order.

Each section shall have signs clearly identifying the location of both the "Section Begins" and "Section Ends". The Sections must be numbered at the time of the Rider's inspection. A machine is considered as being in a section when the front wheel spindle has passed the "section begins" sign and until the time when the front wheel spindle passes the "section ends" sign.

The color codes for the various classes is as follows:

Championship class, Red

Championship class Junior, Blue

Championship class Women, organizer is free to choose a color separate from other classes

Class Over 40+, Green

International classes, organizer is free to choose a color separate from other classes

Where it is found necessary to abandon any section owing to "force majeure" before all riders have passed through then no penalties shall be incurred in this section by any rider.

If there are riders in the queue for this section, then the queue should be formed in the same order at the next section. The total time for the event shall not be modified in the event of any section being abandoned during the Trial.

If any section proves during the first lap to be impossible for all riders (all 5 points) that section shall not be modified for the next lap but may be abandoned at the conclusion of the lap. The penalties incurred by any rider in the section shall be included in that rider's total penalty points for the event.

TL 01.4.1 Section Boundaries

The sections shall be bounded by natural obstacles and strong, easily visible waterproof tape, securely fastened to stakes or trees.

The stakes must be securely fixed to the ground and be spaced close enough to each other to prevent major movement of the tapes. The tape must be at a minimum height of 10 cm above the ground and below a maximum height 30 cm. The actual width of the section defined between the tapes shall be at least 200 cm.

When a tape is used as an external limit of a section or as an internal separation within a section, then the following shall apply. Breaking the tape or passing over a tape so that a wheel touches the ground on the opposite side shall be considered as a failure.

The actual width of the section may be reduced by the use of "gates" indicated by markers, as shown below, with the minimal width between these markers being 120 cm. The Arrows within the gates shall be colored red for the Championship Class blue for the Junior Class.

Riders in the Nordic Championship and Junior Class must travel only between the "gates" for their Class. A rider who passes between the "gates" of another Class – in whatever direction irrespective of if used that day – will be classed as a failure i.e. 5 points. If any tape or any marker or stake is broken or moved then it must be replaced before the passage of the next rider. The Clerk of the Course must ensure that there is an adequate reserve supply of tape and markers available at each section.

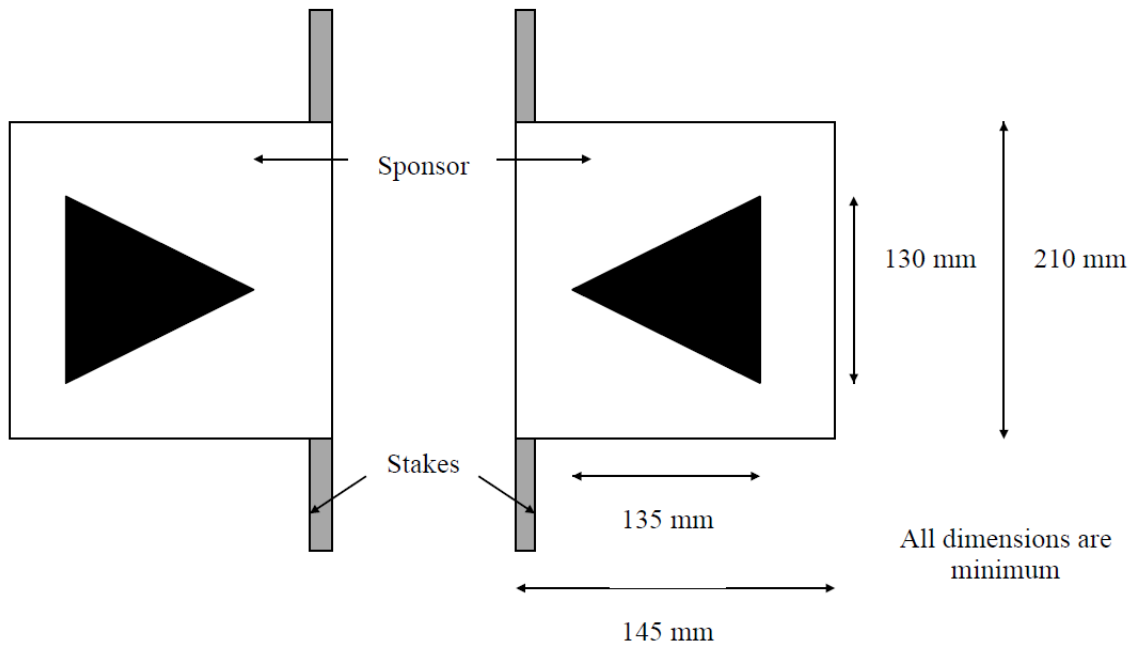

TL 01.5 TIME ALLOWANCE AND CONTROL

TL 01.5.1 Time measurement

In order to carry out his duties, the time control official shall have in his possession an instrument which registers to the tolerance allowed.

The time control official shall have at his disposal a reserve chronometer which registers to the tolerance allowed. Riders must accept any type of timekeeping system approved by the Jury.

TL 01.5.2 Individual and Team Time Allowance

The overall time allowance for each rider [in the individual championship or each rider in the team championship](#) to travel from the start to the lap time control on the final lap subject to TL 01.5.2.1 shall not be more than **6:00 h**.

Irrespective of the actual time a rider starts, the scheduled time for all finishing times will be retained. Time penalties for late starting or late arrival at any other time controls are given in TL 01.10.1.

TL 01.5.2.1 Increase in Individual and Team Time Allowance

The Jury may increase the rider's time ([individual or team championship](#)) allowance by up to a total of 20 minutes. In such a case all riders must be informed of this alteration before the start.

TL 01.5.3 Starting Time and Control

The Organizer must fix the starting time so that the last rider [in the individual championship](#) is able to start no later than 11:00. [The last team in the Team championship can start no later than 10:00](#) The Start Time Control shall be at the starting place with the riders starting from a platform.

TL 01.5.4 Lap Time Control

The lap time control, clearly marked and well visible, shall be located immediately after the final section. Riders will remain subject to the restrictions on repairs and replacements of parts (see TL 01.9.4) until the machine is released by the organizer at the finish point. To travel from the lap time control to the finish point each rider may be allocated a set period of time. This time allowance will be set by the Jury and displayed on a notice at the lap time control. Any rider who exceeds this allowance shall be liable to + 5 points.

TL 01.5.5 Time allowance in sections

The time for riding a section is limited to 1 minute and 30 seconds. Time measurement starts when the front wheel spindle crosses the starting line of the sections and stops when the front wheel spindle crosses the stopping line of the section.

TL 01.6 PRACTICING

Practicing in the sections of the Trial is forbidden under penalty of disqualification.

TL 01.7 RIDERS INSPECTION OF THE SECTIONS

TL 01.7.1 Inspection of the Sections prior to the event.

Inspection of the sections are allowed prior to the start of the event.

TL 01.7.2 Inspection of the Sections during the event.

The riders are allowed to inspect the sections on foot during the event.

Minders are NOT allowed inside the sections unless given permission by the observers **and then only for security reasons while their driver is driving in the section.**

The use of an approved trial helmet is mandatory for riders and minders also when inspecting the sections. Bicycle helmets are not approved helmets for minder use.

01.8 ADMINISTRATION

The Administrative Control shall take place the day prior to the event according to the timetable included at the end of this document.

TL 01.8.1 Riders' Licenses

Riders must be in possession of a National License from their own FMN.

TL 01.8.2 Submission of entries

The Supplementary Regulations must be sent by the organizer to the Nordic FMN's at least 2 Months (60 days) prior to the event.

National teams in Championship Class, Junior Cup, Over-40 Class and Womens Class **must** be submitted by each FMN to the organizer at least 14 days prior to the event.

A rider wishing to enter an event must send to the organizer a completed entry form at least 14 days prior to the event. The organizer will be able to accept entries arriving after the closure of entries, but the entry fee for rider and assistant will then be doubled. The dates for closure of entries will be stated in the Supplementary Regulations (SR).

Riders must state on the Entry Form whether they wish to ride the Championship Class, Junior Class, 40+ Class, or the International Class. A rider who has previously ridden in the current year in one class, may change class, but cannot later revert to the original choice.

If entries are to be limited, the maximum number to be accepted and the method of selection must be stated in the Supplementary Regulations (SR), if prior approval by the NMC meeting has been given. Riders entering for the Championship class shall always be given priority of entry followed by the riders in the Junior Cup and then the Over-40 Class.

No entries shall be accepted after the closing date for receipt of entries as stated in the Supplementary Regulations. In case of a rider entry not being received by the closing date of entries due to administrative problems, the Jury President must satisfy himself that the rider concerned is fully licensed and authorized to compete. In such circumstances, the Jury President decision shall be final.

The entry of a particular make of motorcycle and nomination of a rider having been accepted cannot be changed unless application in writing is made to the Clerk of the Course, giving the reason and permission obtained. Detailed instructions are stated in the SR. The Organizer must confirm, by e-mail, to the FMN of each rider who submits an entry whether the entry is accepted or not.

TL 01.8.2.1 Non-participation in an event

Any rider whose entry for an event has been confirmed to his FMN and who subsequently does not intend to participate must send a valid reason to the organizer by e-mail at least 24 hours prior to the Administrative Control. Any rider who does not participate in the event, or who has not submitted a valid reason, will be reported by the International Jury to his/hers FMN, who may impose a penalty.

TL 01.8.2.2 Team participants and categories

TL 01.8.2.2.1 Participants

All categories are open to teams with riders meeting the criteria of these rules and holding a valid trial license issued by their FMN. The competition is open to teams representing one of the following FMNs: DMU (Denmark), NMF (Norway), SML (Finland), MSI (Iceland), LaMSF (Latvia), LMSF (Lithuania), EMF (Estonia) and SVEMO (Sweden).

TL 01.8.2.2.2 The Nordic Team Trial Championships

Each FMN can enter only one official national team in this category, composed of 1, 2 or 3 riders. Each rider is allowed one minder. The two best results in each section count.

TL 01.8.2.2.3 The Nordic Junior Team Trial Championship

Each FMN can enter only one official national team in this category, composed of 1, 2 or 3 riders. Each rider is allowed one minder. This category is open to riders from the year in which they turn 13 and who are under, or attain, 18 years during the current year. The two best results in each section count.

TL 01.8.2.2.4 The Nordic Women's Team Trial Championship

Each FMN can enter only one official national team in this category, composed of 1, 2 or 3 riders. Each rider is allowed one minder. This category is open to female riders from the year in which they turn 13 years of age. The two best results in each section count.

TL 01.8.2.2.5 The Nordic 40+ Team Trial Championship

Each FMN can enter only one official national team in this category, composed of 1, 2 or 3 riders. Each rider is allowed one minder. This category is open to riders from the year in which they turn 40 years of age. The two best results in each section count.

TL 01.8.2.2.6 Open Classes

One or more Open Classes should be included in each event for riders from the year they turn 13 years of age who will compete either in one of the other classes section route or a own.

NB: There is no overall classification for these class/classes.

TL 01.8.3 Entry fee

The entry fee for the rider shall be maximum € 45:- at the individual championship.

The fee for the Assistant shall be maximum € 20:- at the individual championship.

The entry fee for the rider shall be € 30:- at the team championship.

The fee for the Assistant shall be € 15:- at the team championship.

TL 01.8.4 Riders' bibs

The dimensions must be in accordance with the FIM Trial technical rules.

The bibs of each Class **can** identify the **different** Classes. This may be by color or identification mark.

The rider shall wear the riding bib allocated to him and ensure that the numbers (back and front) are fully visible during the entire competition.

Riders may obliterate any advertisements appearing on the riding bibs which are in direct conflict with the rider's own personal contracts with sponsors. Riders must provide written evidence that such a conflict exists.

When a sponsor has concluded an official contract direct with the FMNR where the events takes place, the wearing of riding bib provided by the organizer is compulsory for all riders and the sponsors' advertisement must not be obliterated.

TL 01.8.5 Registered Assistant (Minder)

Each rider may register one Assistant to accompany him on the course and carry tools.

The registered assistant may use a valid National Trial license in his own country.

The rider and the Assistant must sign a declaration that the rider is responsible for all action of the Assistant.

The Assistant is not be allowed into the boundaries of any section unless specifically allowed by the Section Observer for security reasons.

The Assistant must at all time wear leather boots, long trousers and a long sleeved shirt.

Whilst riding a motorcycle or whilst inside the section boundaries a helmet complying with the Technical rules Appendix "Trial" must be worn.

The Assistant must wear a riding bib in agreement with the Technical Rules Trial Appendix, and in a different color to that of the rider's bib.

The Assistants bib is not transferable and must be worn only by the registered Assistant. In the case of injury a substitute Assistant may be registered. The bib should be visible on the chest of the Assistant and the number at the rear of his helmet during the entire Trial.

The assistants' machines can be subject to technical control at any time during the event for security reasons and regarding sound level.

The rider may receive assistance by any person to repair his machine, or change any unmarked parts, except within the boundary of a section.

Only the rider is allowed to ride or push his machine on the course.

TL 01.8.6 Starting interval

Starting shall be at intervals of 1 minute and 30 seconds [in the Nordic individual championship.](#)
[Starting interval shall be 4 minutes and 30 seconds between each team in the Team championship.](#)

TL 01.8.7 Starting order

The starting order for all riders will be decided by ballot according to Class.

The organizers must ensure that the riders cannot see the starting order when they make their selection (sealed envelopes, etc.).

Riders in the International Class will start first followed by the riders of the Over-40 Class, who will be followed by the riders of the Junior Class and so riders of woman class who will be followed by the riders of the Nordic Championship.

TL 01.9 TECHNICAL

A Technical Control shall take place during the same time period as the Administrative Control. Further Technical Controls may be made at any time.

TL 01.9.1 Equipment of the motorcycle

Motorcycles and their equipment must comply with the FIM Technical rules for Trial.

Tyres must be of the Trials type, in accordance with the Technical rules. Tyres must be normally available from retail and wholesale sources. Prototype tyres are not allowed. Any replacement tyre must be of the same construction, profile, and compound and carry the

same manufacturers mark as the original tyre.

Only the fuels in conformity with the Trial Technical Rules are authorized. Failure to comply with this rule will be penalized by disqualification. Electrically powered bikes are allowed in all categories.

A cut-off switch with a lanyard fixed on the rider must be installed and operational once the rider is on the machine.

Each motorcycle must be clearly marked in front with correct color marking for the class the driver is competing in. Approximately size is of 150 mm², for instance 30x50 mm.

TL 01.9.2 Riders equipment

It is compulsory for the rider to wear a helmet, boots, gloves, arm covering and other clothing requirements as detailed in the FIM Technical Rules Appendix Trial.

With addition of the supplementary rules of the organizing country. This is in case of national differences like mandatory use of back protectors etc.

TL 01.9.3 Sound level Control

Sound level control is not compulsory, but in those cases they are performed will the:

At the preliminary technical control, the sound level of all motorcycles will be measured according to the rules stated in the FIM Technical Rules, Appendix "Trial". Any machine that fails this test may have adjustments made or have parts replaced until the sound level is in accordance with the Code. If a new silencer is fitted then it shall be marked. Only after a successful test will the silencer be marked.

TL 01.10 PENALTIES

TL 01.10.1 Time Penalties with respect to Time Allowances

For each minute or part thereof late arrival at the start: 1 Point

More than 20 minutes late arrival at the start: Disqualification

For each minute or part thereof late at the last lap time control: 1 Point

More than 20 minutes late at the last lap time control: Disqualification

TL 01.10.2 Penalty Points in a Section during the trial

1 Fault in the section 1 point

2 Faults in the section 2 points

more than 2 Faults in the section 3 points

Making a Failure in the section 5 points

Only the greatest penalty, as defined above, shall be counted in the Section.

IN CASE OF DOUBT CONCERNING THE PENALTY, THE OBSERVER WILL ALWAYS

GIVE THE RIDER THE BENEFIT OF THE DOUBT.

Any penalty awarded by the Section Observer, subsequently agreed by the Clerk of the Course to be within the Trial Rules, shall be deemed a Statement of Fact.

TL 01.10.2.1 Definition of Fault

Each contact of any part of the rider or his machine (with exception of the tyres, footrest and the engine protection plate) with the ground or an obstacle (tree, rock, etc.).

Providing that the machine is within the section boundaries, a fault may occur within or outside said boundaries.

TL 01.10.2.2 Definitions of Failure

1) The machine touches the ground with the front or rear wheel outside a boundary

- 2) Breaking a tape defining a section boundary or internal separation.
- 3) The rider or machine breaks, removes, knocks down a marker or marker support causing the Observer to reposition the marker, irrespective of it being used that day.
- 4) One or both wheels rides over, above or on the wrong side of a marker or marker support.
- 5) The rider dismounts from the machine and he has both feet on the ground, on the same side or behind the axle of the back wheel of the machine.
- 6) The motorcycle does a complete loop, crossing its own track with both wheels.
- 7) The rider passes through the gate of another category in either direction, irrespective of it being used that day. *
- 8) The rider is not connected to the cut-off switch with a lanyard whilst he is riding inside a section
- 9) The Assistant comes into the section without the invitation of the Observer.
- 10) The rider or his Assistant changes the condition of a section.
- 11) The rider receives outside physical assistance.
- 12) The rider goes backwards with a foot touching the ground.
- 13) The rider makes a fault while the engine is cut off.

TL 01.10.2.3 Extra Sanction Points

- The Assistant disputes the section official's decision: Yellow Card
- Not attempting the sections in numerical order: **10** points
- Missing a section: 20 points

TL 01.10.2.4 Obstruction

Obstruction is deemed to have occurred when a rider, whilst attempting an observed section, is prevented from making a bona-fide attempt due to some unauthorized obstruction. Should a rider claim an obstruction, the observer may, at his discretion, allow a re-run of the section. The Observers decision as to whether a re-run is permitted is final. Should a re-run be granted the following procedure shall be adopted; The rider will make a complete re-run of the Section using the time control as stated in TL 01.5.5, any marks lost prior to the point of the obstruction on the original attempt shall stand and marks subsequently lost from the point of obstruction added.

TL 01.10.3 Yellow Card

Each Chief Observer shall be issued with a "Yellow Card". The card is recommended to be A6 in size (to fit into a pocket) and be made of a rigid material (card or plastic). Any rider, or Assistant, who refuses to obey the instructions of an Observer or shows disorderly conduct at a Section shall be shown the Yellow Card. The Observer shall then complete a copy of the form "NOTIFICATION" and without delay transmit this information to the Clerk of the Course for further transmission to the Results manager as soon as possible following the incident.

For the extra points to be valid the Notification form must be received by the Results Manager within the deadline of 1 hour and before the publication of the results signed by the Clerk of the Course.

Penalties

- First offense during the event: + 5 extra points
- Second offense during the event: + 5 extra points
- Third offense during the event: Disqualification
- The Jury may take further action for serious offenses.

TL 01.10.4 Disqualification

A rider will be disqualified for any of the following offenses:

- a) Riding a motorcycle without a helmet during the competition (Art.TL 01.9.2).
- b) Missing marking or official substitute marking (Art.TL 01.9.4);
- c) Changing the motorcycle or rider during the event;
- d) Using a non-approved tyre or changing to a tyre of a different construction, profile or compound to the original tyre (Art. TL 01.9.1);
- e) Use of a non-authorized fuel (Art.TL 01.9.1);
- f) Use of banned substances (regardless of sanctions imposed in the FIM Medical Code);
- g) Changing riding bib (Art. TL 01.8.4);
- h) Not rejoining the course at the point where the rider left it (Art. TL 01.3.2);
- i) Practicing in a section (Art. TL 01.6).
- j) Receiving three or more Yellow Cards (Art TL 01.10.4)
- k) Other more serious instance of disorderly conduct towards an official by a rider or his Assistant.

TL 01.11 RECORDING OF SCORES

The rider must be provided with an individual Punch card made from a non-soluble material. The rider is responsible for having his Punch card marked at each section and for handing in his card to the results officials when requested.

In case of mistake on punch card, all squares will be perforated and the square indicating the right penalty will be left free.

A back up score sheet shall be completed at each section showing the scores of all riders.

The Punch Card, supplemented by the Notification sheet, will be used to determine the results and that the back up sheets will only be used if the Punch card is lost or the reading of the Punch Card causes doubt.

TL 01.12 RESULTS AND CLASSIFICATION'S

TL 01.12.1 Event results and classification

Separate printed result classifications must be produced for each class, showing the name of each rider, the FMN, the nationality and the Machine ridden. Each rider's performance in each Section must be shown.

The winner in each class will be the rider with the lowest number of points according to Art. 01.10

TL 01.13 PREMATURE STOPPAGE

If the event is prematurely stopped by the Jury before all of the riders still competing have completed half of the total number of Sections then it shall be declared null and void. If the event is stopped by the Jury at a later stage then the results will remain valid for all sections that all riders still competing have attempted.

If stopped prematurely by the Jury, the event cannot be re-run.

TL 01.14 TIES

TL 01.14.1 Ties at the end of the Event

In the case of ties, the rider with the greatest number of "cleans" (0 point) will be the winner. If a tie still persists, the greatest number of 1 point, then 2 points, then 3 points will be taken into account.

If a tie still persists, the rider who completes the day in the shortest time measured by the second will be deemed the winner.

Ties between teams will be handled as above, with the exception that ALL riders results will counted.

TL 01.15 AWARDS

SVEMO is responsible of ordering the medals.

In each individual class

The winner will receive a gold medal with a ribbon in the organizing country's national colors
Second place will receive a silver medal with a ribbon in the organizing country's national colors.
Third place will receive a bronze medal with a ribbon in the organizing country's national colors.

In each team class

All riders on the winning team and their Team Manager will receive a gold medal with a ribbon in the organizing country's national colors.

All riders on the second best team and their Team Manager will receive a silver medal with a ribbon in the organizing country's national colors.

All riders on the third best team and their Team Manager will receive a bronze medal with a ribbon in the organizing country's national colors.

The organizer of the event is free to organize additional classes other than the official Championships categories. The prizes for these, must be obtained and organized by the organizer separately.

TL 01.15.1 Prize Giving Ceremony and Public interview

A prize giving ceremony shall take place within 15 minutes of the arrival at the finish of the last rider or team. For the ceremony, it is recommended to have an attractively decorated podium in clear view of the public.

TL 01.16 PROTESTS

Protests must be lodged according to the Disciplinary and Arbitration Code of the FIM and Supplementary Regulations and be accompanied by a fee of Euro 50 or the equivalent amount in local currency (convertible), returnable if the protest is justified.

SUPPLEMENTARY REGULATIONS

NMC NORDIC CHAMPIONSHIP

ANNOUNCEMENT

The <club name here> will promote the Nordic Championship on behalf of the <federation name here>. The event will be

held in accordance with the Sporting Code of the FIM Europe together with relevant Appendices of the Nordic Motorsport Council, these Supplementary Regulations and any Final Instructions approved by the Jury. The FIM Environment Code shall apply.

The event will be held on <date here> at <venue name here>.

EMN No 40/# & 43/# & 44/#

ACCESS

Paddock GPS Coordinates: <Latitude coordinates> <Longitude coordinates>

Nearest Airport:

Access Motorway and Exit: Motorway Number: ### Exit number: ###

National Road(s) to Venue: Road number ###

Nearest Town: <Town name> distance: ### km

ADDRESSES AND CONTACT INFORMATION

Organizer of the Event Secretariat of the Event Accommodation Service

Name

Address

Telephone

Fax

e-mail @ @ @

1 ENTRIES

Entries must be made on the official entry form and sent to the Secretary of the meeting.

The rider must specify either Championship class, Woman class, Junior Class, Over-40 Class or International Class (see TL 01.8.2).

Entries must be received by <closing date here>. Entries received after this date and up until four days before the event will be subject to a double entry fee for rider and assistant. <If entries are to be limited, please write the limit number and method of limitation here. If not limited, please delete this text.>

2 TECHNICAL CONTROL AND REGISTRATION

The administrative and technical controls will take place between <open to select time> to the day prior to the event.

Machines must comply with the technical requirements of the FIM Trial Technical Rules and the specifications and exemptions mentioned in the FIM Europe Trial rules.

Sound Control testing will be carried out in accordance with TL 01.9.3.

At the administrative control, the rider must submit his appropriate Rider's License, valid for the event (Art TL 01.8.1). At the technical control, the rider must submit the administrative documents of his motorcycle and a helmet, according to the FIM standards.

3 NUMBERS

The organizers shall issue riding numbers.

4 STARTING ORDER

At the Administrative Control each rider will sign on and take a start position from the appropriate ballot box. (See TL 01.8.7).

5 COURSE

The length of the course is of ## km.

6 PADDOCK / PRACTICE

The Paddock will be opened to all riders from <date and time here>.

The practice area will be opened to all riders from <date and time here>. Any rider found practicing outside of this area may not be allowed to start.

Riders may only visit the Sections at the time stated on the Notice Board in the Paddock.

7 HEADQUARTERS AND JURY MEETINGS

The Headquarters for the event will be <headquarter location here>, and Jury Meetings will be held at <Jury Room location here>.

The first Jury Meeting will be held the day prior to the event at <Open to select time>. The Jury President will call additional Jury Meetings, the times of which will be on the Notice Board.

8 AWARDS AND PRIZE GIVING CEREMONY

The Prize Giving Ceremony will take place within 15 minutes after the last rider has arrived at the finish.

Awards will be presented to the first ## placed riders in each class of the event.

9 ADDITIONAL INFORMATION

Enclosed with these Supplementary Regulations is a hotel list, which includes the locations and the costs.

Also attached is a map showing the main access roads to the event and the precise location of the paddock.

10 OFFICIALS

Name FIM License No

President of the Jury:

FMNR Member of the Jury:

Clerk of the Course:

Chief Technical Steward:

Environment Official:

Chief Timekeeper:

FMN Delegates: In accordance with the FIM Europe Sporting Code.

COMPULSORY NMC STANDARDS FOR ORGANISERS OF NORDIC TRIAL CHAMPIONSHIP

1. FIRST AID-EMERGENCY FACILITIES

Shall be in accordance with the FMNR national rules.

2. SANITARY SERVICES

The organizers of the event must accommodate for a paddock / camping area with toilets, showers (separate for women). Offering electricity is optional and has to be stated in the supplementary regulations as well as stating pricing per vehicle. They must also provide facilities to dispose of rubbish, oils, detergents etc. An area to clean the motorbikes must also be provided which must comply with the FIM Environmental Code.

3. SECTIONS AND COURSE

The Sections must be completely marked out (including numbering) and available for inspection by the Jury President at least 24 hours before the scheduled start time. Regarding the safety, severity and length of the sections the Jury President shall make the final decision. The International Jury must inspect them, at the latest, the day before the competition. During the inspection of the sections by the International Jury, the organizer shall ensure that materials and personnel are available to correct immediately any changes decided.

The spectator access to the sections shall be marked clearly and whenever possible using different routes to those used by the riders to ensure the smooth running of the event (without hindering the participants).

It must be possible for the riders to follow and complete the course (from the paddock to all sections and back) without the use of public roads (unless closed for general traffic with permission from the authorities and guarded by police or officials).

4. SECTION BACK UP SCORE SHEET

A back up score sheet shall be completed at each section showing the scores of all riders. This back up sheet shall be sent immediately at the end of the event directly to the Results Manager.

5. NOTIFICATION DOCUMENT

A Notification document will be supplied to all organizers and this must be completed by the Section Observer for any Correction, or Additional Penalty, that may be awarded. To be valid this document must be signed by the Observer, endorsed by the Clerk of the Course and handed to the Results Manager within 60 minutes of the incident.

6. OBSERVER IDENTIFICATION

The observers must wear uniform (bibs, caps, overalls, etc), so that the riders are able to identify them clearly.

At each section, at least one of the Officials shall have followed a specific training for observer.

These officials should remain at the disposal of the Clerk of the Course until the end of the time limit for protests.

7. PADDOCK

The riders paddock shall:

- Be situated on a flat surface;
- have sufficient area;
- have opened roads to assure, at any time, passage for vehicles to leave the paddock;
- have separated sanitary facilities for men and women, including toilets and showers;
- have a full supply of drinking water;

- be provided with sufficient rubbish containers. The organizer should take care of the cleaning service;
- be provided with containers to receive used oils and lubricants;
- be provided with a special place for the cleaning of the motorbikes (according to Art. 6 of the Environmental Code);
- have a notice board with all the necessary information for the riders.

The installations shall be fully in place for the opening of the Paddock, which must be established on the Thursday prior to the event. If the Paddock is to be open to riders before this time then the actual day of opening and facilities available, (Toilets, Drinking water, Electricity) must be stated on the Supplementary Regulations together with any nightly rate that may be charged.

Note: From the official opening time of the Paddock to the end of the event, the facilities are to be freely available, without charge, to all competitors.

There should be a person responsible for the Paddock and for its general running. The Paddock should wherever possible be located next to an inhabited region and services: hospital, supermarket, pharmacy, service station, etc.

8. NOTICE BOARD

A prominently placed "NOTICE BOARD" shall be installed in the paddock from the opening day, upon which the following information shall be displayed.

- A map of the local town indicating the location of the following: Hospital/Medical Centre, post office, telephone, police station, supermarket and tourist information office.
- Directions to and times of the Practice Area.
- Time and place of the first Jury meeting.
- Time and Place of the Technical and Administrative Controls.
- Time at which the riders may inspect the Sections.

At the appropriate time the following information shall be displayed: Entry list, starting order, provisional results. All information shall be in both official languages.

9. PRACTICE AREA

A practice area (sections) of adequate size must be installed. This practice area must allow riders to practice in accordance with the rules. The characteristic of the terrain should at **least** partially correspond to the sections used in the event. The area has to be marked off clearly, and the access must be marked. It must be possible for the riders to access the practice area at all times ~~that~~ **when** it is open without the need for a driving license or a registered bike.

It is recommended that this area be open to all riders 3 days before the event and the exact date shall be published in the Supplementary Regulations.

It is forbidden to provide sections for the event in this area unless they are clearly marked and fenced prior to the opening of Practice.

10. STARTING TIME

The organizer must fix the starting time to satisfy the requirements of the appropriate rules.

10. STARTING PLACE

The starting area shall allow the riders to travel without being hindered by the spectators. Riders shall start from a platform. A loudspeaker should if possible be installed to call up the riders in the National language.

The starting rostrum should be nicely decorated. A notice board with the latest information for the riders shall be installed just next to the Starting area. The following information shall be displayed: Entry list, Starting order, Provisional results, Official hours, Decisions of the Jury, etc...

A notice board with the results should be installed visibly in order to have clear information.

11. PARKING FOR PRESS, JURY, OFFICIALS

Separated parking places for Press, Jury Members, Delegates and Officials must be installed and specially marked.

12. JURY ROOM

For the meetings of the International Jury a room of adequate size must be prepared to ensure quiet working conditions for the Jury.

For the meeting between the Jury President and the organizers the Clerk of the Course must be in attendance together with the person responsible for the Sections and the Secretary of the Meeting.

13. PRESS ROOM

If possible, a separate room for [the](#) press should be [available](#).

14. ADMINISTRATIVE AND TECHNICAL CONTROLS

The administrative and technical controls shall be carried out at the times specified in the appropriate rules.

15. ADDITIONAL INFORMATION

The following information shall be enclosed with the Supplementary Regulations.

- A hotel list which includes the locations and the costs.
- A map showing the main access roads to the event and the precise location of the paddock.
- The location and distance from the start of the nearest international airport.

16. AWARDS

Awards shall be presented to at least the first three placed riders in each Class. Souvenirs may be given to all riders.

17. PRIZE GIVING CEREMONY

The prize giving ceremony shall take place in the starting area within 15 minutes of the arrival at the finish of the last rider.

It is recommended to have a nicely decorated podium in clear view of the public. The first three placed riders should receive a trophy together with any appropriate ceremonial gift.

DUTIES OF THE ASSISTANT (MINDER)S

TASKS

The rider and the Assistant must sign a declaration that the rider is responsible for all action of the Assistant.

The Assistant must ~~always~~ wear leather boots, trousers and a helmet complying with the Technical rules, Appendix "Trial", whilst riding a motorcycle.

The Assistant must wear a riding bib, supplied by the organizer, with the corresponding riding number to that of the rider he is registered with, but of different color. This bib is not transferable and must be worn only by the registered Assistant.

RIGHTS

The Assistant can follow his rider on the course, respecting the organizer's marks.

He may assist the rider anywhere on the course, to repair his machine or change any unmarked parts.

He may hold his rider's machine anywhere on the course.

He may go inside the section for the security of his rider, if he gets the authorization of the sections official.

RESTRICTIONS

He is not allowed to go into the boundaries of any section unless specially invited by an Official (for security reasons).

He is not allowed to push the rider's motorcycle on the course, while the rider is completing the course.

He is not allowed to circulate with his rider's motorcycle, neither on the course, nor in the sections, while the rider is completing the course.

He is not allowed to modify the sections' marking, to change the position of the tapes or of the arrows.

He is not allowed to discuss with the officials about the penalties' application.

He is not allowed to replace the rider at the prize giving ceremony.

Timetable for Nordic Trial Championship

Day	Time	Nordic Individual Championship	Nordic Team Championship
FRIDAY	10:00-11:00 11:00-12:00 12:00-16:00	Meeting Jury President & FMN representatives visit sections	
	17:00-19:30		Administrative & Technical inspections
	20:00	Jury meeting	
SATURDAY	11:00		Last rider starts
		Jury meeting immediately after the prize-giving ceremony	Jury meetings with representation of all delegates are held on demand and when there is a registered protest.
	18:00-20:30		Administrative & technical inspections for Teams
SUNDAY	10:00		Last team starts
		Jury meeting immediately after the prize-giving ceremony	Jury meetings with representation of all delegates are held on demand and when there is a registered protest.